

Single-Stage Coalescer Housings

HP Series

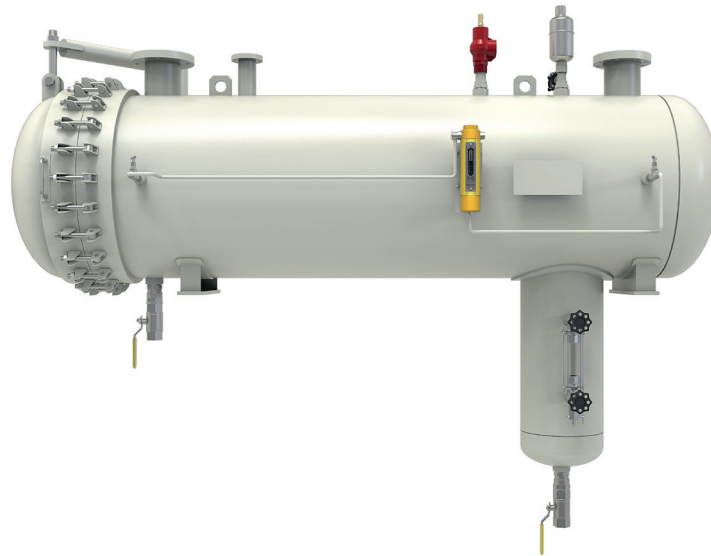

Facet HP Series single-stage coalescers use wafer repacks to remove gross amounts of water and solids from hydrocarbons. They are available in several standard sizes to accommodate flows from 10 to 2000 gpm (38 to 7570 lpm). They provide protection to filtration systems from gross amounts of water and solids that are commonly carried through inbound transport pipelines.

HP Series housings offer an option of using coalescer cartridges for more efficient solids separation and liquid-liquid water separation. Use of an adaptor kit permits returning to the use of repacks at any time.

HP Series housings have no internal moving parts and are designed for easy servicing, thereby reducing maintenance costs. Each housing is manufactured with quality workmanship and materials to give long- lasting and dependable service.

Variations from standard design are available in higher pressures, other materials, special connections or other quick opening closures.

Standard Design Features

- Body: Carbon steel construction
- ASME Code, Section VIII, Div. 1, stamped and certified
- Designed for 150 psi @ 250 °F (10.34 bar @ 121 °C)
- Housing Closure:
 - Blind cover on housings less than 14" (356 mm) OD
 - Swing bolt closure on housings 14" (356 mm) OD and larger
- Housing Covers:
 - Removable on housing up to 14" (356 mm) OD
 - Hinged on housings 14" (356 mm) thru 36" (914 mm) OD
 - Rotating davits on housings 42" (1067 mm) OD and larger
- Head Gasket: Buna-N — other material available by request
- Exterior: Prime coated
- Saddle supports for pier mounting

Options

- Steel stands available
- Internal epoxy coating

Standard Connections

- Inlet and outlet: 150# RF (ANSI) flanged
- All other connections are 3000# NPT female type couplings

Single-Stage Coalescer Housings

HP Series

GUIDELINE FOR FLOW CAPACITIES OF EQUIPMENT

(Subject to Limitations Contained in Footnotes)

MODEL	For Excelsior Type Cartridges Only ^{See (3) (4) & Media Chart} HP Series Flow Rate in gpm For Specific Gravity Ranges as Shown at 60 °F					MODEL	For Glass Fiber, Carbon Steel, Stainless Steel or Combination Packs ^{(4) & Media Chart} HPX Series Flow Rate in gpm For Specific Gravity Ranges as Shown at 60 °F				
	0.55 - 0.65	0.66 - 0.72	0.73 - 0.77	0.78 - 0.82	0.83 - 0.86		0.55 - 0.65	0.66 - 0.72	0.73 - 0.77	0.78 - 0.82	0.83 - 0.86
HP-10	10	10	8	6	5	HPX-10	6	6	5	4	3
HP-25	25	23	18	15	11	HPX-25	16	15	12	10	7
HP-50	43	40	31	26	20	HPX-50	29	27	21	17	13
HP-80	70	65	50	43	32	HPX-80	47	43	33	28	21
HP-100	100	90	75	60	45	HPX-100	65	60	50	40	30
HP-120	125	110	90	75	55	HPX-120	84	73	60	50	35
HP-150	160	150	120	100	75	HPX-150	105	100	80	65	50
HP-180	205	190	150	125	95	HPX-180	135	125	100	85	63
HP-200	255	230	185	155	115	HPX-200	170	150	120	100	75
HP-300	370	330	270	225	165	HPX-300	245	220	180	150	110
HP-500	585	530	425	350	265	HPX-500	390	350	280	230	175
HP-750	840	750	600	510	375	HPX-750	560	500	400	340	250
HP-1000	1200	1080	860	720	540	HPX-1000	800	720	570	480	360
HP-1500	1550	1400	1130	940	700	HPX-1500	1030	930	750	625	465
HP-1800	1960	1800	1430	1200	900	HPX-1800	1300	1200	960	800	600
HP-2000	2400	2200	1750	1425	1100	HPX-2000	1600	1460	1160	950	730
Estimated Effic.^{(1) (3)}	99.95%	98-99%	98-99%	97-98%	97-98%	Estimated Effic.^{(2) (3)}	See Media Chart				

(1) Estimated efficiency is based on conditions where the inlet water content is between 0.5% and 3% by volume, pH value between 5 and 9, operating temperature does not exceed 250 °F, and interfacial tension between liquid and water phase is not less than 35 dynes per centimeter (See Media Chart).

(2) Estimated efficiency is based on conditions where the inlet water content is between 0.5% and 3% by volume, and interfacial tension between the liquid and water phase is not less than 35 dynes per centimeter. (See Media Chart).

(3) Efficiencies shown are estimated based on general conditions normally encountered in such applications. These efficiencies are not warranted until all data have been submitted on Facet Application Information Sheet for evaluation and statement of efficiency.

(4) Applications for liquid temperatures less than 60 °F should be referred either to your distributor or to the factory.

EQUIPMENT SELECTION GUIDELINES

Based on Normal Operating Conditions and Subject to Limitations Shown in Flow Guideline

Performance Guidelines		Moderately Efficient Removal of Gross Solids and Water from Heavy and Light Liquids
When use	To remove	
Butane / Propane	Solids	RG4
	Entrained Water	RG6-7
	Water Haze	R6
Aviation Gasoline	Solids	RG4
	Entrained Water	RG7
	Water Haze	R7
Motor Gasolines	Solids	RG4
	Entrained Water	RG7
	Water Haze	R7
Naphtha (Light)	Solids	RG4
	Entrained Water	RG7
	Water Haze	Q ⁽¹⁾
Kerosene and Jet Fuel	Solids	RG4
	Entrained Water	RG7
	Water Haze	Q ⁽¹⁾
Diesel Fuel	Solids	RG4
	Entrained Water	RG8
	Water Haze	N ⁽¹⁾
Fuel Oil	Solids	RG4
	Entrained Water	RG8
	Water Haze	N ⁽¹⁾
Hydraulic Oil	Solids	RG4
	Entrained Water	RM9
	Water Haze	N ⁽¹⁾
Lube Oils	Solids	RG4
	Entrained Water	RM9
	Water Haze	N ⁽¹⁾

Recommendations ⁽¹⁾	
R = Recommended	
Q = With Qualification	
N = Not Recommended	
Contaminant Load ⁽¹⁾	
Solids	Water
L = 0-0.5 ppm	L = 0-0.5% Vol
M = 0.6-1.0 ppm	M = 0.6-3.0% Vol
G = Greater than 1.0 ppm	G = Greater than 3.0% Vol
Solids Removal	Water Removal
1 = Nominal 2 to 5μ	6 = Excellent = 100%
2 = Nominal 5 to 10μ	7 = Good = 99.5%
3 = Nominal 15 to 25μ	8 = Moderate = 98%
4 = Nominal 40μ	9 = Fair = 95%
1) Contact Factory for Other Recommendations	

MEDIA CHART

MEDIA	NOMINAL SOLIDS RETENTION	MAX. TEMP.	pH*	EFFICIENCY
Excelsior	40 - 60	250°F	5-9	(1)
Glass Fiber	30 - 40	350°F	less than 10	99.9%
Stainless Steel	50 - 60	600°F	more than 4	98%
Carbon Steel	50 - 60	600°F	more than 4	98%
Combination	30 - 40	350°F	less than 10	98%

* Optimum operating condition and should not in itself be restrictive.

(1) Estimated efficiency is based on conditions where the inlet water content is between 0.5% and 3% by volume, pH value between 5 and 9, operating temperature does not exceed 250°F, and interfacial tension between liquid and water phase is not less than 35 dynes per centimeter

Single-Stage Coalescer Housings

HP Series

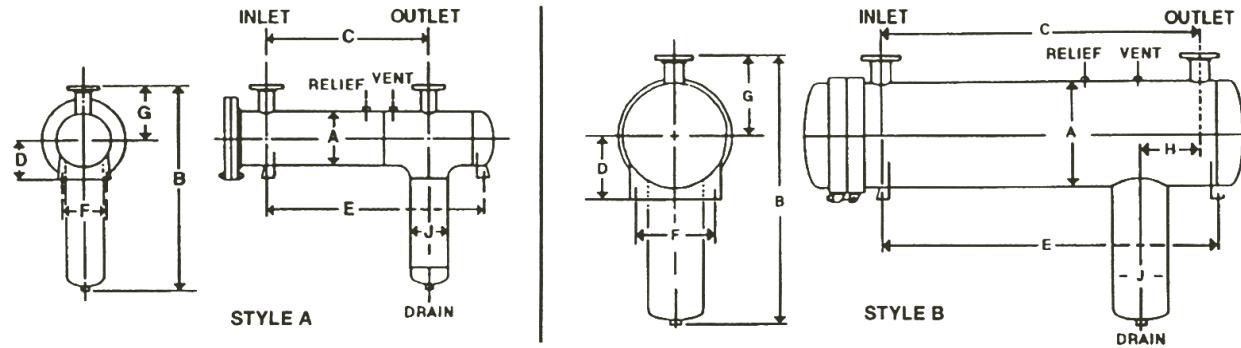

DIMENSIONS

MODEL NUMBER	DIMENSIONS																		
	A		B		C		D		E		F		G		H		J		
	in	mm	in	mm	in	mm	in	mm	in	mm	in	mm	in	mm	in	mm	in	mm	
STYLE A																			
HP-10	4 1/2	114	33 1/2	851	24	610	5	127	30 1/2	775	22	559	8	203	—	—	4 1/2	114	
HP-25	6 5/8	168	37 1/2	953	33	838	6	152	41	1041	24	610	9	229	—	—	6 5/8	168	
HP-50	8 5/8	219	45	1143	39	991	7	178	48 1/2	1232	30	762	10	254	—	—	8 5/8	219	
HP-80	10 3/4	273	46	1168	42	1067	8	203	54	1372	30	762	11	279	—	—	8 5/8	219	
HP-100	12 3/4	324	47	1193	48	1219	9	229	60 1/2	1537	30	762	12	305	—	—	8 5/8	219	
HP-120	14	356	48 1/2	1232	50	1270	10 1/2	268	47 1/2	1206	31	787	13	330	—	—	8 5/8	219	
STYLE B																			
HP-150	16	406	51	1295	60	1524	11	279	66	1676	32	813	14	356	4	102	8 5/8	219	
HP-180	18	457	54	1372	66	1676	12	305	72	1829	33	838	15	381	9	229	10 3/4	273	
HP-200	20	508	56	1422	72	1829	13	330	78	1981	34	864	16	406	9	229	12 3/4	324	
HP-300	24	610	60	1524	75	1905	15	381	81	2057	36	914	18	457	9	229	12 3/4	324	
HP-500	30	762	69	1753	80	2032	18	457	86	2184	42	1067	21	533	12	305	14	356	
HP-750	36	914	82	2083	92	2337	21	559	98	2489	51	1295	24	610	12	305	16	406	
HP-1000	42	1067	91	2311	106	2692	24	610	114	2896	57	1448	27	686	12	305	16	406	
HP-1500	48	1219	95	2413	120	3048	27	686	128	3251	57	1448	30	762	12	305	20	508	
HP-1800	54	1372	110	2794	132	3353	30	762	142	3607	69	1753	33	838	10	254	20	508	
HP-2000	60	1524	119	3023	144	3658	30	762	154	3912	75	1905	36	914	10	254	20	508	

STANDARD HOUSING DATA

MODEL NUMBER	LIQUID VOLUME (APPROXIMATE)		SHIPPING WEIGHT (APPROXIMATE)		CONNECTIONS												
					INLET/OUTLET FLANGED		VENT & RELIEF		DRAIN		LEVEL GAUGE		LEVEL CONTROL				
	gal	ltr	lbs	kgs	in	mm	in	mm	in	mm	in	mm	in	mm	in	mm	
STYLE A																	
HP-10	2.4	9	240	109	1	25	1/2	13	1/2	13	3/4	19	3/4	19	3/4	19	
HP-25	10.0	38	310	141	1 1/2	38	1/2	13	1/2	13	3/4	19	3/4	19	3/4	19	
HP-50	18.2	69	780	354	1 1/2	38	1/2	13	3/4	19	3/4	19	3/4	19	3/4	19	
HP-80	30.0	113	800	363	2	51	1/2	13	3/4	19	3/4	19	3/4	19	3/4	19	
HP-100	46.6	176	1550	703	3	76	3/4	19	3/4	19	3/4	19	3/4	19	1	25	
HP-120	64.7	245	1700	772	3	76	3/4	19	3/4	19	3/4	19	3/4	19	1 1/2	38	
STYLE B																	
HP-150	77.7	294	1815	824	3	76	3/4	19	3/4	19	3/4	19	3/4	19	1 1/2	38	
HP-180	120.0	454	2000	907	3	76	3/4	19	1	25	3/4	19	3/4	19	1 1/2	38	
HP-200	152.0	575	2100	954	3	76	1	25	1	25	3/4	19	3/4	19	1 1/2	38	
HP-300	201.6	763	2300	1045	4	102	1	25	1 1/2	38	3/4	19	3/4	19	1 1/2	38	
HP-500	313.4	1186	3100	1407	6	152	1	25	1 1/2	38	3/4	19	3/4	19	1 1/2	38	
HP-750	610.5	2310	4000	1816	6	152	1 1/2	38	2	51	3/4	19	3/4	19	1 1/2	38	
HP-1000	742.6	2810	4600	2088	8	203	1 1/2	38	2	51	3/4	19	3/4	19	2	51	
HP-1500	969.0	3668	5200	2361	8	203	1 1/2	38	2	51	3/4	19	3/4	19	2	51	
HP-1800	1428.0	5405	6200	2815	10	254	1 1/2	38	2	51	3/4	19	3/4	19	2	51	
HP-2000	2116.8	8012	8000	3632	10	254	1 1/2	38	2	51	3/4	19	3/4	19	2	51	

NOTE: All dimensions, weights, and volumes are approximate and should be used for estimating only.